

BERNARDO®

www.bernardo-spain.com

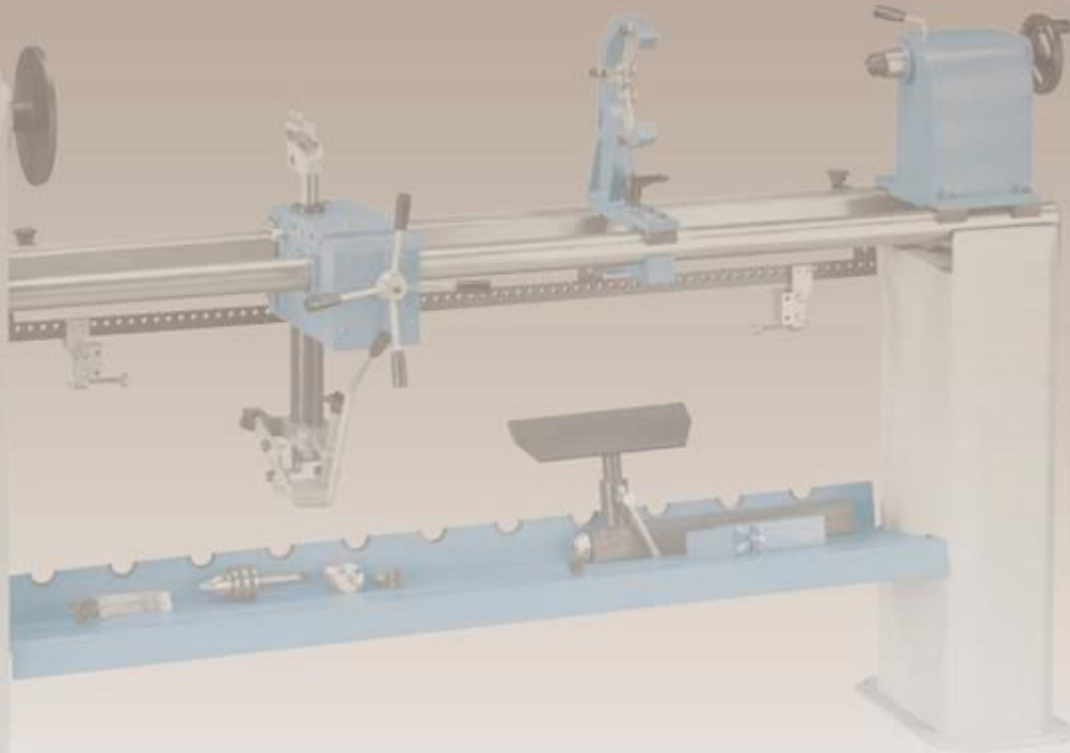

03/2022

WOODTURNING LATHES



VDM 500
HCL 600 P
HCL 620
KDM 1000 eco
KDM 1100
KDH 1100
CL 1300
CL 1500
HCL 1200
HCL 1200 Top

DM 305 V
DM 450
DM 450 V
DB 450
DM 480 VD

Woodturning lathe

DM 305 V

The DM 305 V lathe features an electronic, steplessly adjustable speed setting as part of the standard accessories. The great price to performance ratio makes this model an attractive choice for hobby craftsmen.

- Steplessly adjustable spindle speed allows for optimal adjustment to workpiece
- Machine bed, tail- and spindle stock consists of solid grey cast-iron to eliminate vibrations
- Large speed range from 750 - 3200 rpm, steplessly adjustable
- Robust spindle, mounted with precision to ensure concentricity
- Solid tool rest ensures sufficient support for chisels
- Extensive range of extra equipment to widen the choice of applications
- Tailstock spindle features hole to allow processing of long workpieces
- Quick clamping lever allows for fast clamping of tailstock to machine bed

BERNARDO
www.bernardo-spain.com
HOBBY



4-jaw chuck 125 mm / M 33 x 3,5 mm (Option)



Serially with tool rest 110 mm and 175 mm.



Stepless adjustment ensures ideal speed settings.



Self-centering chuck 40 / 70 (optional)



Collet chuck system M 24 / M 33, 6 pcs. (optional)

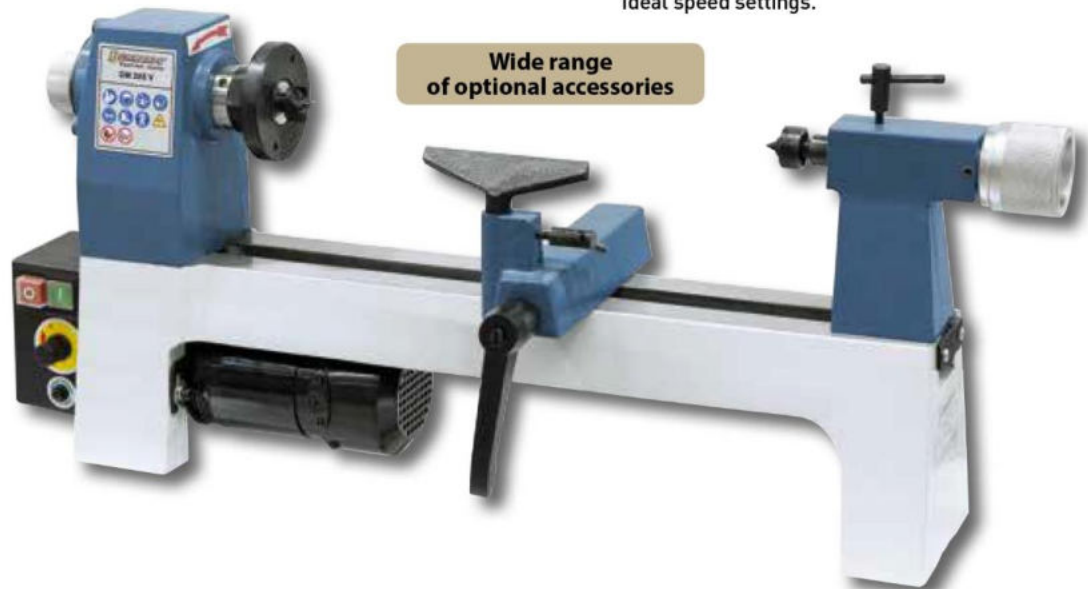

Wide range of optional accessories

Standard accessories:

- 2 pcs. tool rest 110 / 175 mm
- 2 pcs. face plate 80 / 145 mm
- Spore drive center
- Live center
- Stepless speed adjustment
- Tools

Stepless speed adjustment

Technical data

DM 305 V

Distance between centers	345 mm
Working diameter	
- over guideway	210 mm
- over support	140 mm
Spindle speeds	750 - 3200 rpm, stepless
Spindle thread	M 33 x 3,5 mm
Taper of tailstock sleeve	MT 1
Travel of tailstock sleeve	38 mm
Motor power output S ₁ 100%	0,25 kW (0,34 HP)
Motor power input S _e 40%	0,31 kW (0,42 HP)
Voltage	230 V
Machine dimension (W x D x H)	660 x 250 x 310 mm
Weight approx.	20 kg
Art. no.	10-1069

Optional accessories:

- Collet chuck system M 24 / M 33, 6 pcs.
- Drive center set M 33 x 3,5, 7 pcs.
- Drive center set M 33 x 3,5 incl. 2 live center, 9 pcs.
- 3-jaw chuck 125 mm / M 33 x 3,5 mm
- 4-jaw chuck 125 mm / M 33 x 3,5 mm
- Self-centering chuck 40 / 70
- Power chuck set 6 pcs., with collet M 33 x 3,5 mm
- Profi-chisel set HSS, 8 pcs. / set B
- Mini-chisel set HSS, 5 pcs. / set E
- Mini-chisel set HSS, 3 pcs. / set F
- Economy live center PC - MT 1

Art. no. excl. VAT

- 10-5050
- 10-5051
- 10-5052
- 10-6004
- 10-6002
- 10-6020
- 10-6030
- 10-7002
- 10-7006
- 10-7007
- 22-1000

Woodturning lathe

DM 450

The DM 450 woodturning lathe features a solid grey cast construction to eliminate vibrations and ensure for top accuracy. The model can be equipped with an optional available bed extension, whereby the distance between center will be increased up to 980 mm.

- Ideal for craftsmen with high demands
- Robust tailstock with MT 2 taper and quick clamping lever
- Solid construction eliminates vibrations
- Clearly arranged switches and control elements on the front of machine
- Tool rest 150 mm and face plate 75 mm are part of standard equipment
- Extensive range of extra equipment to widen the choice of applications
- Quick clamping lever allows for easy locking of tool rest



For clamping of asymmetrical workpieces the machine can be equipped with a 4-jaw independent chuck.



3-jaw chuck 150 mm / M 33 (optional)



Quick clamping lever allows for easy clamping of tool rest.



The compact tailstock can easily be locked into position by one-hand lever.



4-jaw chuck 125 mm / M 33 (optional)



Self-centering chuck 40 / 70 (optional)

Best Price



Picture shows optionally available bed extension to 980 mm.

Technical data

DM 450

Distance between centers	420 mm
Distance between centers with extension*	980 mm
Working diameter	
- over guideway	260 mm
- over support	190 mm
Spindle speeds	500 - 3200 rpm
Speed steps	5
Spindle thread	M 33 x 3,5 mm
Taper of tailstock sleeve	MT 2
Travel of tailstock sleeve	50 mm
Motor power output S ₁ 100%	0,44 kW (0,6 HP)
Motor power input S _s 40%	0,55 kW (0,75 HP)
Voltage	230 V
Machine dimension (W x D x H)	780 x 260 x 380 mm
Weight approx.	33 kg
Art. no.	10-1070

* optional

Standard accessories:

- Tool rest 150 mm
- Face plate 75 mm
- Spore drive center
- Live center
- Tools

BERNARDO
www.bernardo-spain.com
HOBBY

Optional accessories:

- Bed extension f. DM 450 / DM 450 V
- Collet chuck system M 24 / M 33, 6 pcs.
- Drive center set M 33 x 3,5, 7 pcs.
- Drive center set M 33 x 3,5 incl. 2 live center, 9 pcs.
- 4-jaw chuck 125 mm / M 33 x 3,5 mm
- 3-jaw chuck 150 mm / M 33 x 3,5 mm
- Self-centering chuck 40 / 70
- Chuck M 70 with dovetail jaws type A
- Profi-chisel set HSS, 8 pcs. / set B
- Mini-chisel set HSS, 5 pcs. / set E

Art. no. excl. VAT

- 10-3005
- 10-5050
- 10-5051
- 10-5052
- 10-6002
- 10-6005
- 10-6020
- 10-6052
- 10-7002
- 10-7006

BERNARDO
www.bernardo-spain.com

Woodturning lathe

DM 450 V

The DM 450 V lathe features an electronic, steplessly adjustable speed setting as part of the standard accessories. The great price to performance ratio makes this model an attractive choice for hobby craftsmen.

- Ideal for craftsmen with high demands
- Comes complete with stepless speed adjustment
- Robust tailstock with MT 2 taper and quick clamping lever
- Solid construction eliminates vibrations
- Clearly arranged switches and control elements on the front of machine
- Tool rest 150 mm and face plate 75 mm are part of standard equipment
- Extensive range of extra equipment to widen the choice of applications
- Quick clamping lever allows for easy locking of tool rest



For clamping of asymmetrical workpieces the machine can be equipped with a 4-jaw independent chuck.



Quick clamping lever allows for easy clamping of tool rest.



The compact tailstock can easily be locked into position by one-hand lever.



Self-centering chuck 40 / 70 (optional)

**Best
Price**

BERNARDO
HOBBY



The stepless speed adjustment allows for the speed to be optimally adjusted to the workpiece.



**Stepless
speed adjustment**

Technical data

DM 450 V

Distance between centers	420 mm
Distance between centers with extension*	980 mm
Working diameter	
- over guideway	260 mm
- over support	190 mm
Spindle speeds	L: 650 - 1450 rpm M: 1250 - 2800 rpm H: 1600 - 3800 rpm
Speed steps	3
Spindle thread	M 33 x 3,5 mm
Taper of tailstock sleeve	MT 2
Travel of tailstock sleeve	50 mm
Motor power output S ₁ 100%	0,37 kW (0,5 HP)
Motor power input S _e 40%	0,50 kW (0,68 HP)
Voltage	230 V
Machine dimension (W x D x H)	820 x 260 x 380 mm
Weight approx.	34 kg
Art. no.	10-1075

* optional

Standard accessories:

- Tool rest 150 mm
- Face plate 75 mm
- Spore drive center
- Live center
- Stepless speed adjustment
- Tools

Picture shows optionally available bed extension to 980 mm.

Optional accessories:

- Bed extension f. DM 450 / DM 450 V
- Collet chuck system M 24 / M 33, 6 pcs.
- Drive center set M 33 x 3,5, 7 pcs.
- 4-jaw independent chuck 150 mm / M 33 x 3,5 mm
- 4-jaw chuck 125 mm / M 33 x 3,5 mm
- Self-centering chuck 40 / 70
- Chuck M 70 with dovetail jaws type A
- Profi-chisel set HSS, 8 pcs. / set B
- Mini-chisel set HSS, 5 pcs. / set E

Art. no.	excl. VAT
10-3005	
10-5050	
10-5051	
10-6000	
10-6002	
10-6020	
10-6052	
10-7002	
10-7006	

Woodturning lathe

DB 450

The DB 450 woodturning lathe features a solid grey cast construction to eliminate vibrations and ensure for top accuracy. The generous range of standard accessories (LED- display, stepless speed adjustment etc.) makes this model ideal for semi-professionals.

- Quick clamping lever allows for fast clamping of tailstock to machine bed
- Machine bed, tailstock and headstock made from rigid grey cast iron to eliminate vibrations
- 24 rests assist when locking the workpiece
- Complete with steel support, easy to adjust to various workpiece diameters
- Bed extension optionally available to extend distance between centers to 1070 mm
- Large speed range (2 steps) from 480 – 3800 rpm
- Tailstock spindle features hole to allow processing of long workpieces
- Robust spindle, mounted with precision to ensure concentricity



Robust belt drive ensures for optimal transmission to spindle.

Stepless speed adjustment

Complete with tool holder on the rear to secure optimal storage for tools.



LED display allows for convenient speed readout.



Optional accessory: Chuck M 95 with dovetail jaws type A



Stepless adjustment ensures ideal speed settings.

Including LED speed indication

Standard accessories:

- Tool rest 150 mm
- Face plate 80 mm
- Live center MT 2
- Stepless speed adjustment
- LED speed indication
- Spore drive center 25 mm
- Tool storage
- Working light
- Tools



Picture with optional bed extension

Technical data

DB 450

Distance between centers	420 mm
Distance betw. centers w. extension*	1070 mm
Working diameter	
- over guideway	300 mm
- over support	230 mm
Spindle speed	480 - 3800 rpm, stepless
Speed steps	L 480 - 1800 rpm, H 900 - 3800 rpm
Spindle thread	M 33 x 3,5 mm
Taper of tailstock sleeve	MT 2
Travel of tailstock sleeve	50 mm
Motor power output S ₁ 100%	0,55 kW (0,75 HP)
Motor power input S _a 40%	0,75 kW (1,0 HP)
Voltage	230 V
Machine dimension (W x D x H)	970 x 300 x 440 mm
Weight approx.	36 kg
Art. no.	10-1077

* Option

Optional accessories:

Bed extension f. DB 450	Art. no.	excl. VAT
Collet chuck system M 24 / M 33, 6 pcs.	10-3006	
Drive center set M 33 x 3,5 incl. 2 live center, 9 pcs.	10-5050	
4-jaw independent chuck 150 mm / M 33 x 3,5 mm	10-5052	
4-jaw chuck 125 mm / M 33 x 3,5 mm	10-6000	
Self centering chuck 40 / 70	10-6002	
Chuck M 95 with dovetail jaws type A	10-6020	
Profi-chisel set HSS, 8 pcs. / set B	10-6053	
Mini-chisel set HSS, 5 pcs. / set E	10-7002	
	10-7006	

BERNARDO[®]
www.bernardo-spain.com

Woodturning lathe

DM 480 VD

The DM 480 VD woodturning lathe features a solid grey cast construction to eliminate vibrations and ensure top accuracy. The generous range of standard accessories (LED- display, stepless speed adjustment etc.) makes this model ideal choice for hobby craftsmen.

- Quick clamping lever allows for fast clamping of tailstock to machine bed
- Large speed range (2 steps) from 300 - 3700 rpm
- Tailstock spindle features hole to allow processing of long workpieces
- Machine bed, tailstock and headstock made from rigid grey cast iron to eliminate vibrations
- Robust spindle, mounted with precision to ensure concentricity
- Bed extension optionally available to extend distance between centers to 1020 mm
- Quick clamping lever allows for easy locking of tool rest
- Digital display allows for convenient adjustment of speed settings



LED display allows for convenient speed readout.



4-jaw chuck 150 mm / M 33 (optional)



Sleeve features bore which is ideal for eg. creating cable shafts in lamp bases.



The power-chuck set Premium M 70, consisting of several chuck devices increases the number of applications significantly (optional extra).

BERNARDO
www.bernardo-spain.com
HOBBY



Serially with tool rest 150 mm and 300 mm.

NEW



Including
LED speed indication

Stepless
speed adjustment

Technical data

DM 480 VD

Distance between centers	460 mm
Distance between centers with extension*	1020 mm
Working diameter	
- over guideway	310 mm
- over support	240 mm
Spindle speeds	300 - 3700 rpm, stepless
Speed steps	L 300 - 1200 ¹ /min, H 1000 - 3700 ¹ /min
Spindle thread	M 33 x 3,5 mm
Taper of tailstock sleeve	MT 2
Travel of tailstock sleeve	55 mm
Motor power output S ₁ 100%	0,75 kW (1,0 HP)
Motor power input S ₆ 40%	1,1 kW (1,5 HP)
Voltage	230 V
Machine dimension (W x D x H)	950 x 300 x 410 mm
Weight approx.	38 kg
Art. no.	10-1074

* optional

Standard accessories:

- 2 pcs. tool rest 150 / 300 mm
- Face plate 80 mm
- Spore drive center
- Live center
- Stepless speed adjustment
- LED speed indication
- Tools

Picture shows optionally available bed extension to 1020 mm.

Optional accessories:

	Art. no.	excl. VAT
Bed extension	10-3005	
Collet chuck system M 24 / M 33, 6 pcs.	10-5050	
Drive center set M 33 x 3,5, 7 pcs.	10-5051	
4-jaw independent chuck 150 mm / M 33 x 3,5 mm	10-6000	
4-jaw chuck 150 mm / M 33 x 3,5 mm	10-6003	
Self centering chuck 40 / 70	10-6020	
Power chuck set Premium M 70	10-5065	
Profi-chisel set HSS, 8 pcs. / set B	10-7002	
Mini-chisel set HSS, 5 pcs. / set E	10-7006	

Professional woodturning lathe **VDM 500**

The VDM 500 woodturning lathe features a solid grey cast construction to eliminate vibrations and ensure for top accuracy. The generous range of standard accessories (LED- display, stepless speed adjustment etc.) makes this model ideal for semi-professionals.

- Quick clamping lever allows for fast clamping of tailstock to machine bed
- Machine bed, tailstock and headstock made from rigid grey cast iron to eliminate vibrations
- 24 rests assist when locking the workpiece
- Complete with steel support, easy to adjust to various workpiece diameters
- Large speed range (3 steps) from 250 - 3550 rpm
- Tailstock spindle features hole to allow processing of long workpieces
- Robust spindle, mounted with precision to ensure concentricity
- Comes complete with right and left turning device



Comes complete with a digital display to allow for convenient speed adjustment.



Repositioning the V-belt allows for easy change of the transmission ratio.



Serially with tool rest 200 mm.



Sleeve features bore which is ideal for eg. creating cable shafts in lamp bases.



Including LED speed indication

Stepless speed adjustment

Optional accessories:

	Art. no.	excl. VAT
Universal-stand ULEG	10-4005	
Collet chuck system M 24 / M 33, 6 pcs.	10-5050	
Drive center set M 33 x 3,5, 7 pcs.	10-5051	
Power chuck set Premium M 95	10-5063	
4-jaw independent chuck 150 mm / M 33 x 3,5 mm	10-6000	
4-jaw chuck 125 mm / M 33 x 3,5 mm	10-6002	
Self centering chuck 40 / 70	10-6020	
Profi-chisel set HSS, 6 pcs. / set A	10-7001	
Profi-chisel set HSS, 8 pcs. / set B	10-7002	
Starter-chisel set HSS, 5 pcs. / set D	10-7004	
Mini-chisel set HSS, 5 pcs. / set E	10-7006	
Economy live center PC - MT 2	22-1001	

Technical data

VDM 500

Distance between centers	520 mm
Working diameter	
- over guideway	360 mm
- over support	260 mm
Spindle speeds	250 - 3550 rpm, stepless
Speed steps	L 250 - 720 / M 600 - 1700 / H 1200 - 3550 rpm
Spindle thread	M 33 x 3,5 mm
Taper of tailstock sleeve	MT 2
Travel of tailstock sleeve	70 mm
Motor power output S ₁ 100%	0,75 kW (1,0 HP)
Motor power input S ₆ 40%	1,1 kW (1,5 HP)
Voltage	230 V
Machine dimension (W x D x H)	1100 x 450 x 500 mm
Weight approx.	50 kg
Art. no.	10-1078

Standard accessories:

- Tool rest 200 mm
- Face plate 100 mm
- Live center MT 2
- Stepless speed adjustment
- LED speed indication
- 2x spore drive center 25 mm
- Tools

BERNARDO[®]
www.bernardo-spain.com

Professional woodturning lathe

HCL 600 P

- Solid tailstock sleeve with MT 2 taper and bore to allow operating of long workpieces
- Quick clamping lever ensures fast clamping of tailstock to machine bed
- Includes steel tool rest, easily adjustable for various workpiece diameters
- Heavy cast-iron construction eliminates vibrations
- Digital display allows for convenient adjustment of speed settings
- Comes complete with right and left turning device
- Precisely bedded spindle ensures high concentricity
- Smooth running, powerful DC drive, steplessly adjustable



The powerful drive motor guarantees high torque even at low speed.



Robust belt drive ensures for optimal transmission to spindle.



Chuck M 115 with dovetail jaws type A (optional)



Quick clamping lever allows for easy clamping of tool rest.



Complete with tool holder to secure optimal storage for tools.

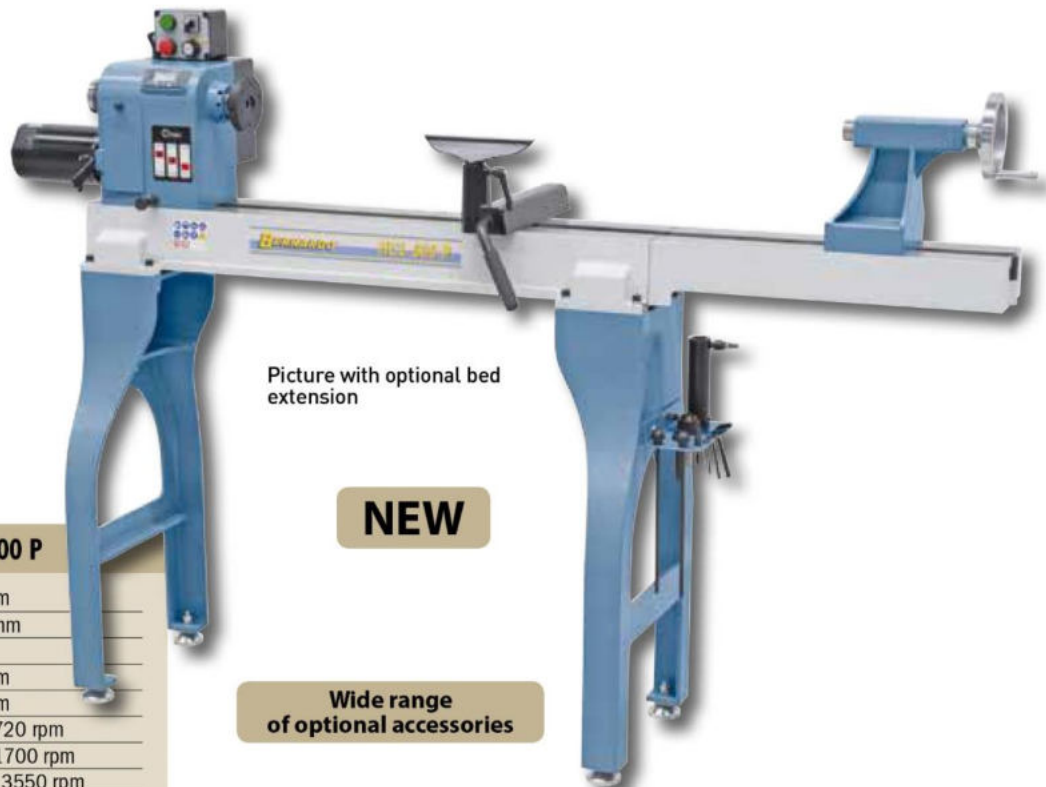

Picture with optional bed extension

NEW

Wide range of optional accessories

Serially equipped with left and right turning

Technical data

HCL 600 P

Distance between centers	600 mm
Distance between centers with extension*	1180 mm
Working diameter	
- over guideway	370 mm
- over support	270 mm
Spindle speed, stepless	250 - 720 rpm
	550 - 1700 rpm
	1200 - 3550 rpm
Speed steps	stepless, 3 steps
Spindle thread	M 33 x 3,5 mm
Tailstock	
Taper of tailstock sleeve	MK 2
Travel of tailstock sleeve	95 mm
Motor power output S ₁ 100%	0,75 kW (1,0 HP)
Motor power input S ₂ 40%	1,1 kW (1,5 HP)
Voltage	230 V
Machine dimension (W x D x H)	1500 x 540 x 1180 mm
Weight approx.	125 kg
Art. no.	10-1182

* optional



The spindle unit can travel longitudinally and can be locked into any position.

The HCL 600 P lathe features an electronic, steplessly adjustable speed setting as part of the standard accessories which allows ideal adjustment to each workpiece. This model is predominately used among experienced, high-level amateurs.

HCL 600 P



Thanks to the optional glide bowl turner's toolrest set, a wide variety of machining operations can be carried out quickly and easily.

Solid tailstock sleeve with MT 2 taper and bore to allow operating of long workpieces.

Best Price



The optionally available outboard turning device (Ø 690 mm) can also be used as bed extension (1180 mm)

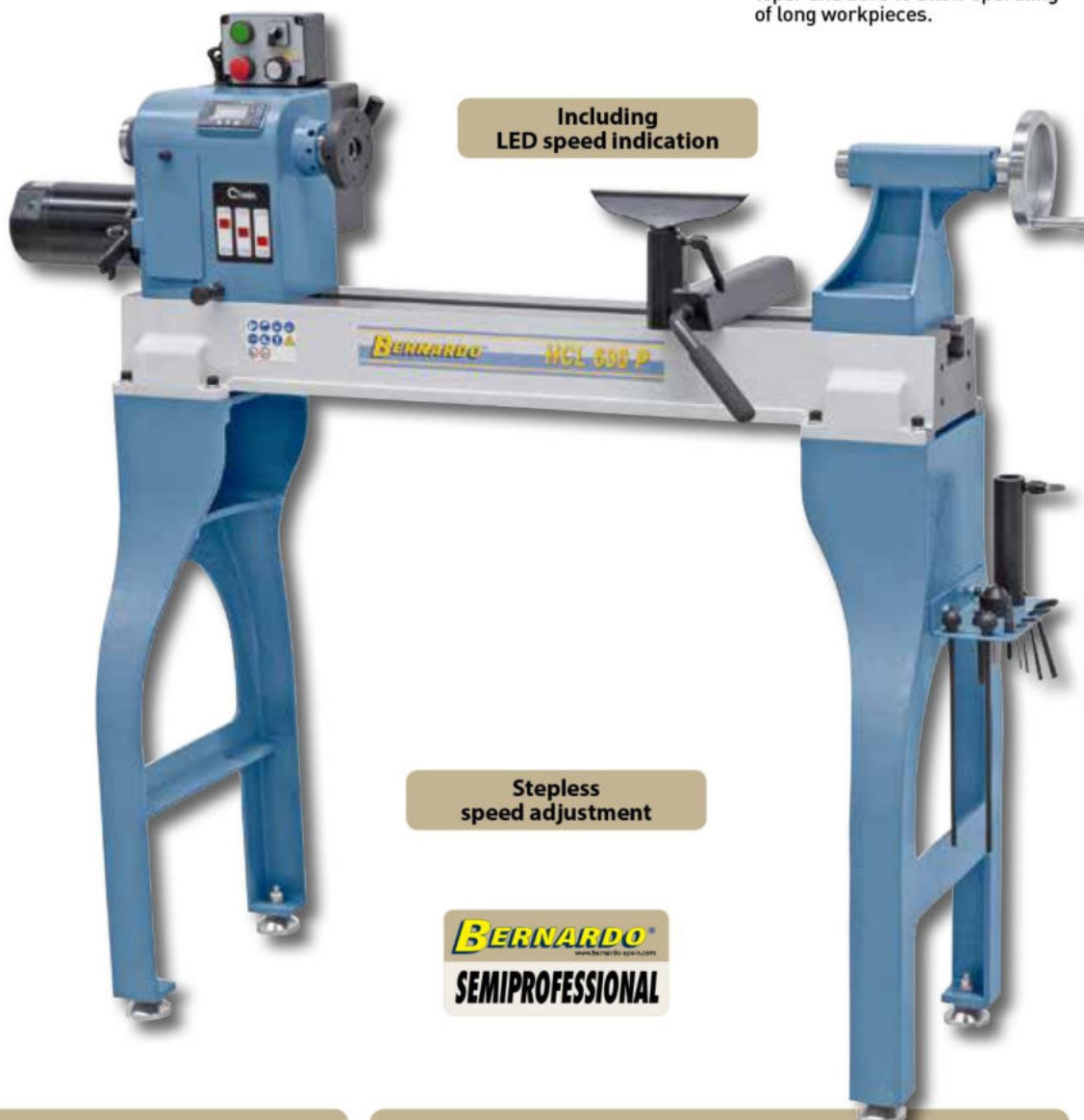

Including LED speed indication

Stepless speed adjustment

BERNARDO
SEMIPROFESSIONAL

Standard accessories:

- Tool rest 200 mm
- Face plate 100 mm
- Live center
- Spore drive center
- Tools

Optional accessories:

- Outboard turning attachment
- Collet chuck system M 24 / M 33, 6 pcs.
- Drive center set M 33 x 3,5, 7 pcs.
- Drive center set M 33 x 3,5 incl. 2 live center, 9 pcs.
- Glide bowl turner's toolrest set 4 pcs.
- Power chuck set Premium M 115
- Chuck M 115 with dovetail jaws type A

Art. no.	excl. VAT
10-3007	
10-5050	
10-5051	
10-5052	
10-5062	
10-5064	
10-6054	

Optional accessories:

- 4-jaw independent chuck 150 mm / M 33
- Self-centering chuck 40 / 70, M 33 x 3,5 mm
- Profi-chisel set HSS, 6 pcs. / set A
- Profi-chisel set HSS, 8 pcs. / set B
- Mini-chisel set HSS, 5 pcs. / set E
- Economy live center PC - MT 2
- Sweeper for woodturning lathe

Art. no.	excl. VAT
10-6000	
10-6020	
10-7001	
10-7002	
10-7006	
22-1001	
10-4003	

Professional woodturning lathe

HCL 620

- Solid tailstock sleeve with MT 2 taper and bore to allow operating of long workpieces
- Delta-frequency inverter ensures variable speed adjustment with optimal torque
- Quick clamping lever ensures fast clamping of tailstock to machine bed
- Includes steel tool rest, easily adjustable for various workpiece diameters
- Heavy cast-iron construction eliminates vibrations
- Digital display allows for convenient adjustment of speed settings
- Comes complete with right and left turning device
- Precisely bedded spindle ensures high concentricity



Serially with tool rest 300 mm.



Power chuck set Premium M 115, Dovetail jaws type A



Power chuck set Premium M 115, Stepped jaws



Power chuck set Premium M 115, Wide jaws striated inside/outside



The optionally available dust extractor allows for clean working conditions.



Power chuck set Premium M 115, Pin jaws 25 mm



Power chuck set Premium M 115, Bowl reversing jaws



Sleeve features bore which is ideal for eg. creating cable shafts in lamp bases.

Technical data

HCL 620

Distance between centers	620 mm
Distance between centers with extension*	1200 mm
Working diameter	
- over guideway	400 mm
- over support	310 mm
Spindle speed, stepless	0 - 1350 rpm 0 - 3000 rpm
Speed steps	stepless, 2 steps
Spindle thread	M 33 x 3,5 mm
Tailstock	
Taper of tailstock sleeve	MT 2
Travel of tailstock sleeve	105 mm
Motor power output S ₁ 100%	1,1 kW (1,5 HP)
Motor power input S ₆ 40%	1,5 kW (2,0 HP)
Voltage	230 V
Machine dimension (W x D x H)	1480 x 520 x 1200 mm
Weight approx.	150 kg
Art. no.	10-1183

* optional

Including
LED speed indication

Stepless
speed adjustment



The optionally available outboard turning device (Ø 720 mm) can also be used as bed extension (1200 mm)

The HCL 620 woodturning lathe features a solid grey cast construction to eliminate vibrations and ensure for top accuracy. The generous range of standard accessories (LED- display, stepless speed adjustment etc.) makes this model ideal for semi-professionals.

HCL 620



Thanks to the optional glide bowl turner's toolrest set, a wide variety of machining operations can be carried out quickly and easily.

Comes complete with a digital display to allow for convenient speed adjustment.

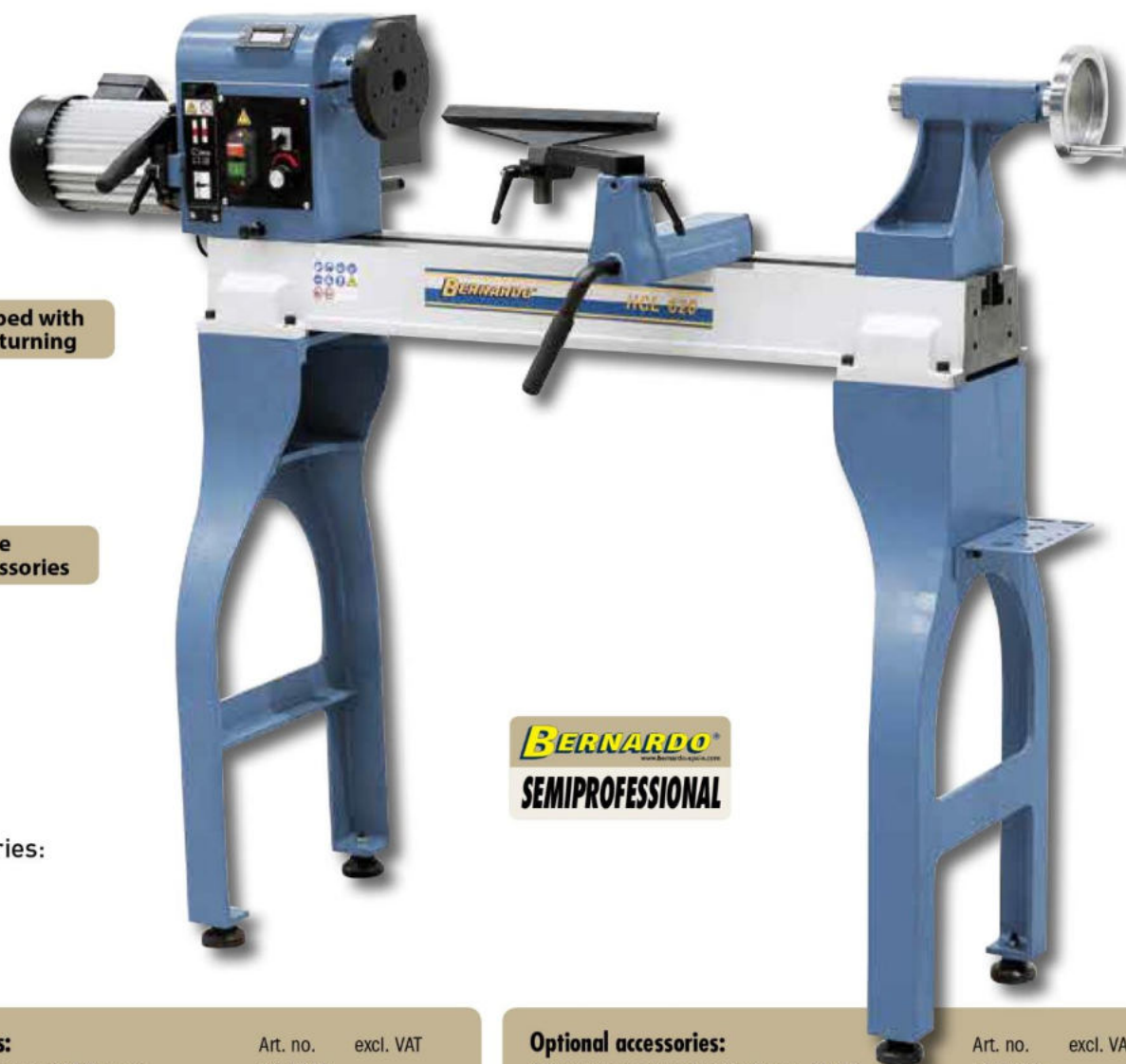

Serially equipped with left and right turning

Wide range of optional accessories

BERNARDO
SEMIPROFESSIONAL

Standard accessories:

- Tool rest 300 mm
- Face plate 150 mm
- Live center
- Spore drive center
- Frequency inverter
- Tools

Optional accessories:

- Outboard turning attachment (Ø 720 mm)
- Collet chuck system M 24 / M 33, 6 pcs.
- Drive center set M 33 x 3,5, 7 pcs.
- Drive center set M 33 x 3,5 incl. 2 live center, 9 pcs.
- Glide bowl turner's toolrest set 4 pcs.
- Chuck M 115 with dovetail jaws type A
- Power chuck set Premium M 115

Art. no.	excl. VAT
10-3007	
10-5050	
10-5051	
10-5052	
10-5062	
10-6054	
10-5064	

Optional accessories:

- 4-jaw independent chuck 150 mm / M 33
- Self-centering chuck 40 / 70, M 33 x 3,5 mm
- Profi-chisel set HSS, 6 pcs. / set A
- Profi-chisel set HSS, 8 pcs. / set B
- Mini-chisel set HSS, 5 pcs. / set E
- Economy live center PC - MT 2
- Sweeper for woodturning lathe

Art. no.	excl. VAT
10-6000	
10-6020	
10-7001	
10-7002	
10-7006	
22-1001	
10-4003	

BERNARDO
www.bernardo-spain.com

Copying woodturning lathes

KDM 1000 eco

- Copying device allows copying of original parts or templates
- Large speed range from 500 – 2000 rpm, steplessly adjustable
- Solid, precisely bedded spindle ensures high concentricity
- High-quality belt drive ensures optimal power transmission from motor to spindle
- Extensive range of extra equipment to widen the choice of applications
- Clearly arranged switches and control elements on the front of machine
- The extensive range of accessories includes: 300 mm tool rest, 150 mm face plate, live centre and spore drive centre
- Steplessly adjustable spindle speed allows for optimal adjustment to workpiece



Serially with tool rest 300 mm.



Power chuck set Premium M 115, Dovetail jaws type A



Power chuck set Premium M 115, Stepped jaws



Power chuck set Premium M 115, Wide jaws striated inside/outside



Stepless speed adjustment

Technical data

KDM 1000 eco

Distance between centers	1000 mm
Working diameter	
- over guideway	350 mm
- at copying	160 mm
Spindle speed, stepless	500 – 2000 rpm
Spindle thread	M 33 x 3,5 mm
Taper of tailstock sleeve	MT 2
Travel of tailstock sleeve	65 mm
Copying length	1000 mm
Motor power output S ₁ 100%	0,55 kW (0,75 HP)
Motor power input S _e 40%	0,75 kW (1,0 HP)
Voltage	230 V or 400 V
Machine dimension (W x D x H)	1500 x 500 x 1210 mm
Weight approx.	68 kg
Art. no.	10-1093 (230 V) 10-1094 (400 V)

Optional accessories:

	Art. no.	excl. VAT
Copying knife in HSS-quality for KDM 1000 eco	10-4004	
Sweeper for woodturning lathe	10-4003	
Collet chuck system M 24 / M 33, 6 pcs.	10-5050	
Drive center set M 33 x 3,5, 7 pcs.	10-5051	
Drive center set M 33 x 3,5 incl. 2 live center, 9 pcs.	10-5052	
Power chuck set Premium M 115	10-5064	
4-jaw independent chuck 150 mm / M 33 x 3,5 mm	10-6000	
4-jaw chuck 125 mm / M 33 x 3,5 mm	10-6002	
Self-centering chuck 40 / 70	10-6020	
Chuck M 115 with dovetail jaws type A	10-6054	
Power chuck set 6 pcs., with collet M 33 x 3,5 mm	10-6030	
Profi-chisel set HSS, 6 pcs. / set A	10-7001	
Profi-chisel set HSS, 8 pcs. / set B	10-7002	
Standard-chisel set carbon, 6 pcs. / set C	10-7003	
Starter-chisel set HSS, 5 pcs. / set D	10-7004	
Mini-chisel set HSS, 5 pcs. / set E	10-7006	

The copying woodturning lathe KDM 1000 eco is serially equipped with a copying device, which allows copying of original parts or templates. Additionally this machine features a stepless speed adjustment. The attractive price-to-performance ratio make this machine the ideal entry-level model.

KDM 1000 eco

BERNARDO
www.bernardo-spain.com
HOBBY



Part of the standard equipment is a copying device for efficient copying of original parts or templates.

The solid variator-drive guarantees ideal power transmission



Stepless adjustment ensures ideal speed settings.



Solid tailstock sleeve with MT 2 taper



**Best
Price**

VOLTAGE

Alternatively in
230 V or 400 V

**Wide range
of optional accessories**

Standard accessories:

- Tool rest 300 mm
- Face plate 150 mm
- Live center
- Spore drive center
- Copying device
- Stepless speed adjustment
- Stand
- Tools



Power chuck set Premium M 115,
Bowl reversing jaws



Power chuck set Premium M 115,
Pin jaws 25 mm

BERNARDO[®]
www.bernardo-spain.com

Copying woodturning lathes **KDM 1100** **KDH 1100**

- Copying device allows copying of original parts or templates
- Tailstock sleeve with bore ensures convenient processing of long workpieces
- Digital display guarantees easy speed adjustment
- Model KDH comes complete with a robust cast-iron machine base
- Stepless speed setting allows optimal adjustment to each workpiece
- Solid, precisely bedded spindle ensures high concentricity
- Turnable spindle stock for working outside of the machine bed
- Grey cast-iron construction for vibration-free work
- High-quality belt drive ensures optimal power transmission from motor to spindle
- Quick clamping lever enables fast locking of tailstock onto machine bed

VOLTAGE

Alternatively in
230 V or 400 V



3-jaw chuck 150 mm (optional).



4-jaw chuck 150 mm (optional).



Self-centering chuck 40/70 (optional).



BEST PRICE!

Technical data

	KDM 1100	KDH 1100
Distance between centers	1100 mm	1100 mm
Working diameter		
- over guideway	370 mm	370 mm
- at copying	160 mm	160 mm
Spindle speed, stepless	500 - 2000 rpm	500 - 2000 rpm
Spindle thread	M 33 x 3,5	M 33 x 3,5 mm
Taper of tailstock sleeve	MT 2	MT 2
Travel of tailstock sleeve	50 mm	50 mm
Copying length	850 mm	850 mm
Motor power output S ₁ 100%	0,75 kW (1,0 HP)	0,75 kW (1,0 HP)
Motor power input S ₆ 40%	1,1 kW (1,5 HP)	1,1 kW (1,5 HP)
Voltage	230 V or 400 V	230 V or 400 V
Machine dimension (W x D x H)	1650 x 750 x 1150 mm	1650 x 750 x 1210 mm
Weight approx.	92 kg	128 kg
Art. no.	10-1105 (230 V) 10-1095 (400 V)	10-1111 (230 V) 10-1112 (400 V)

Optional accessories:

	Art. no.	excl. VAT
Steady rest f. KDM 1100 / KDH 1100	10-4000	
Copying knife in HSS-quality for KDM 1100 / KDH 1100	10-4001	
Copying device Deluxe	10-1116	
Sweeper for woodturning lathe	10-4003	
Collet chuck system M 24 / M 33, 6 pcs.	10-5050	
Drive center set M 33 x 3,5, 7 pcs.	10-5051	
Power chuck set Premium, M 115	10-5064	
4-jaw independent chuck 150 mm / M 33 x 3,5 mm	10-6000	
4-jaw chuck 125 mm / M 33 x 3,5 mm	10-6002	
Self-centering chuck 40 / 70	10-6020	
Chuck M 115 with dovetail jaws type A	10-6054	
Profi-chisel set HSS, 6 pcs. / set A	10-7001	
Profi-chisel set HSS, 8 pcs. / set B	10-7002	
Starter-chisel set HSS, 5 pcs. / set D	10-7004	
Mini-chisel set HSS, 5 pcs. / set E	10-7006	
Economy live center PC - MT 2	22-1001	

Both KDM and KDH woodturning lathes come complete with a copying device as well as an extensive range of standard accessories. The solid cast construction and the attractive price-to-performance ratio make these machines the ideal entry-level model.

KDM 1100 KDH 1100



Spindle stock tilts 90° to allow for processing of large workpieces.



Sleeve features bore which is ideal for eg. creating cable shafts in lamp bases.



Solid variator drive ensures effective speed transmission from motor to spindle.



Comes complete with a digital display to allow for convenient speed adjustment.



Optionally available with steady rest.



BERNARDO
www.bernardo-spain.com
HOBBY

Including digital readout

Standard accessories:

- Tool rest 300 mm
- Face plate 150 mm
- Live center
- Spore drive center
- Copying device
- Stepless speed adjustment
- Digital speed indication
- Stand
- Tools



Part of the standard equipment is a copying device for efficient copying of original parts or templates.

BERNARDO[®]
www.bernardo-spain.com

Copying woodturning lathes

CL 1300 CL 1500

- The extensive range of accessories includes: 290 mm tool rest, 200 mm face plate, live centre and spore drive centre
- Copying device for copying of original parts or from templates
- Tailstock sleeve features drilled passageway bore to process long workpieces
- Powerful drive motor designed for challenging operations
- High-quality belt drive, featuring four speed settings, allows for optimal transmission
- Solid, grey cast-iron construction allows for operating without vibrations
- Ergonomically arranged switches and control elements on front of machine
- Solid, precisely bedded spindle ensures high concentricity
- Extensive range of accessories guarantees optimal price to performance ratio



Power chuck set Premium M 115, Dovetail jaws type A



Power chuck set Premium M 115, Stepped jaws



Power chuck set Premium M 115, Wide jaws striated inside/outside



Complete with integrated copying device to allow copying of original parts or templates.



Power chuck set Premium M 115, Pin jaws 25 mm



Power chuck set Premium M 115, Bowl reversing jaws



Solid headstock guarantees thorough processing free from vibrations. Picture shows 4-jaw chuck 150 mm / M 33 (optional)



Balanced drive wheels and high-quality belt ensure extremely smooth operation

Technical data	CL 1300	CL 1500
Distance between centers	1300 mm	1500 mm
Working diameter		
- over guideway	430 mm	430 mm
- over support	160 mm	160 mm
- at copying*	160 mm	160 mm
Spindle speeds	500 / 1000 / 1950 / 2800 rpm	500 / 1000 / 1950 / 2800 rpm
Spindle thread	M 33 x 3,5 mm	M 33 x 3,5 mm
Tailstock		
Taper of tailstock sleeve	MT 2	MT 2
Travel of tailstock sleeve	100 mm	100 mm
Copy attachment		
Copying length	1300 mm	1500 mm
Max. copying depth	45 mm	45 mm
Motor power output S ₁ 100%	1,1 kW (1,5 HP)	1,1 kW (1,5 HP)
Motor power input S ₆ 40%	1,5 kW (2,0 HP)	1,5 kW (2,0 HP)
Voltage	400 V	400 V
Machine dimension (W x D x H)	2100 x 700 x 1170 mm	2300 x 700 x 1170 mm
Weight approx.	218 kg	228 kg
Art. no.	10-1150	10-1155

* to templates

**Best
Price**

Standard accessories:

- Copying device
- Steady rest
- Tool rest 290 mm
- Face plate 200 mm
- Live center MT 2
- Spore drive center diam. 40 mm
- Drill chuck 3 - 16 mm / B 16
- Drill chuck arbor MT 2 - B 16
- V- Cutter knife in HSS-quality

The powerful copying woodturning lathes for the experienced turners combine optimal performance, state-of-the-art design, high safety and accuracy. The solid spindle is precisely bedded, features four compatible speed settings and guarantees optimal torque even when processing oversize workpieces.

CL 1300 CL 1500



The optionally available dust extractor allows for clean working conditions.



Quick clamping lever allows for easy clamping of tool rest.



Steady rest for shaft diameters up to 90 mm as standard.



Single-hand lever allows for convenient clamping of tailstock to machine bed.

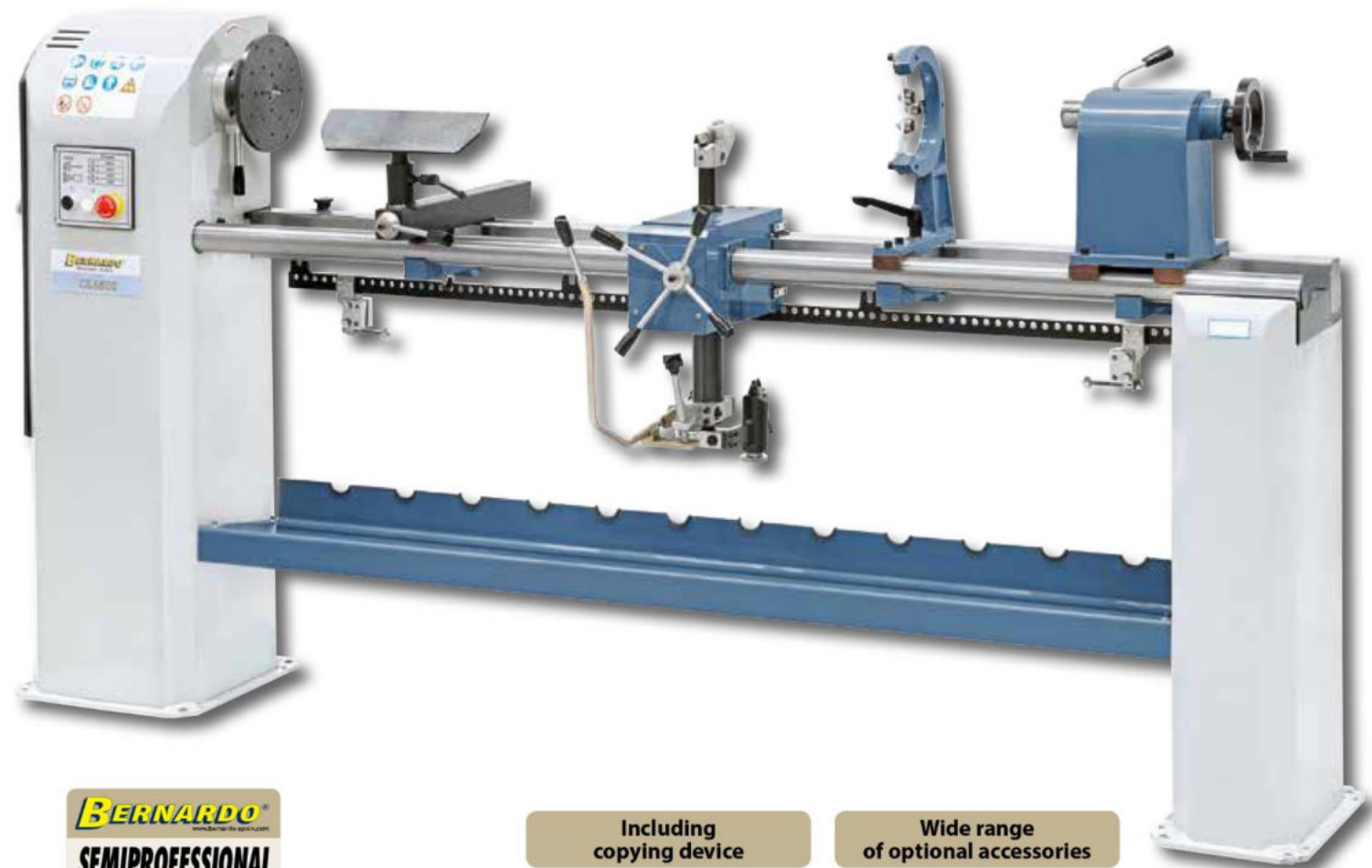

BERNARDO
www.bernardo-spain.com
SEMIPROFESSIONAL

Including copying device

Wide range of optional accessories

Optional accessories:

Sweeper for woodturning lathe
V-cutter knife in HSS-quality
Collet chuck system M 24 / M 33, 6 pcs.
Drive center set M 33 x 3,5, 7 pcs.
Power chuck set Premium M 115
Self-centering chuck 40 / 70
Chuck M 115 with dovetail jaws type A
Ripple jaws f. chuck M 115

Art. no.	excl. VAT
10-4003	
10-5010	
10-5050	
10-5051	
10-5064	
10-6020	
10-6054	
10-60665	

Optional accessories:

Dovetail jaws type B f. chuck M 115
4-jaw independent chuck 150 mm / M 33 x 3,5 mm
Profi-chisel set HSS, 6 pcs. / set A
Profi-chisel set HSS, 8 pcs. / set B
Standard-chisel set carbon, 6 pcs. / set C
Starter-chisel set HSS, 5 pcs. / set D
Mini-chisel set HSS, 5 pcs. / set E
Economy live center PC - MT 2

Art. no.	excl. VAT
10-60666	
10-6000	
10-7001	
10-7002	
10-7003	
10-7004	
10-7006	
22-1001	

BERNARDO
www.bernardo-spain.com

Professional woodturning lathe

HCL 1200

- Quick clamping lever ensures fast clamping of tailstock to machine bed
- Outboard turning attachment optionally available for processing of oversize workpieces
- Includes steel tool rest, easily adjustable for various workpiece diameters
- Heavy cast-iron construction eliminates vibrations
- Digital display allows for convenient adjustment of speed settings
- Comes complete with right and left turning device
- Delta-frequency inverter ensures variable speed adjustment with optimal torque
- Precisely bedded spindle ensures high concentricity



The optionally available dust extractor allows for clean working conditions.



Power chuck set Premium M 115, Dovetail jaws type A



Power chuck set Premium M 115, Stepped jaws



Power chuck set Premium M 115, Wide jaws striated inside/outside



Solid tailstock sleeve with MT 2 taper and bore to allow operating of long workpieces.



Power chuck set Premium M 115, Pin jaws 25 mm



Power chuck set Premium M 115, Bowl reversing jaws



Digital display - as part of standard equipment - ensures comfortable, smooth speed setting.



The powerful drive motor guarantees high torque even at low speed.



Repositioning the V-belt allows for easy change of the transmission ratio.



The spindle unit can travel longitudinally and can be locked into any position.

Technical data

HCL 1200

Distance between centers	1200 mm
Working diameter	
- over guideway	450 mm
- over support	350 mm
Spindle speed, stepless	0 - 1300 rpm
	0 - 3200 rpm
Speed steps	stepless, 2 steps
Spindle thread	M 33 x 3,5 mm
Tailstock	
Taper of tailstock sleeve	MT 2
Travel of tailstock sleeve	110 mm
Motor power output S ₁ 100%	1,5 kW (2,0 HP)
Motor power input S _e 40%	2,2 kW (3,0 HP)
Voltage	230 V
Machine dimension (W x D x H)	2100 x 550 x 1300 mm
Weight approx.	186 kg
Art. no.	10-1185

The HCL 1200 lathe features an electronic, steplessly adjustable speed setting as part of the standard accessories which allows ideal adjustment to each workpiece. This model is predominantly used among experienced, high-level amateurs.

HCL 1200



Thanks to the optional glide bowl turner's toolrest set, a wide variety of machining operations can be carried out quickly and easily.

The outboard turning device ensures hassle-free processing of large workpiece diameters (Ø 810 mm).

Picture with optionally available copying device Deluxe (copying length 1000 mm) for efficient copying of original parts or templates.



**Best
Price**

Standard accessories:

- Tool rest 360 mm
- Face plate 150 mm
- Live center
- Spore drive center
- Frequency inverter
- Tools

Serially equipped with
left and right turning

BERNARDO
SEMIPROFESSIONAL

Optional accessories:

	Art. no.	excl. VAT
Outboard turning attachment	10-4002	
Copying device Deluxe	10-1116	
Collet chuck system M 24 / M 33, 6 pcs.	10-5050	
Drive center set M 33 x 3,5, 7 pcs.	10-5051	
Glide bowl turner's toolrest set 4 pcs.	10-5062	
Power chuck set Premium M 115	10-5064	
4-jaw independent chuck 150 mm / M 33	10-6000	

Optional accessories:

	Art. no.	excl. VAT
Self-centering chuck 40 / 70, M 33 x 3,5 mm	10-6020	
Chuck M 115 with dovetail jaws type A	10-6054	
Profi-chisel set HSS, 6 pcs. / set A	10-7001	
Profi-chisel set HSS, 8 pcs. / set B	10-7002	
Mini-chisel set HSS, 5 pcs. / set E	10-7006	
Economy live center PC - MT 2	22-1001	
Sweeper for woodturning lathe	10-4003	

BERNARDO
www.bernardo-spain.com

Professional woodturning lathe

HCL 1200 Top

- Quick clamping lever ensures fast clamping of tailstock to machine bed
- Outboard turning attachment optionally available for processing of oversize workpieces
- Includes steel tool rest, easily adjustable for various workpiece diameters
- Heavy cast-iron construction eliminates vibrations
- Digital display allows for convenient adjustment of speed settings
- Comes complete with right and left turning device
- Delta-frequency inverter ensures variable speed adjustment with optimal torque
- Precisely bedded spindle ensures high concentricity



The optionally available dust extractor allows for clean working conditions.



Power chuck set Premium M 115, Dovetail jaws type A



Power chuck set Premium M 115, Stepped jaws



Power chuck set Premium M 115, Wide jaws striated inside/outside



Solid tailstock sleeve with MT 2 taper and bore to allow operating of long workpieces.



Power chuck set Premium M 115, Pin jaws 25 mm



Power chuck set Premium M 115, Bowl reversing jaws



Digital display - as part of standard equipment - ensures comfortable, smooth speed setting.

BERNARDO
SEMIPROFESSIONAL

Technical data	HCL 1200 Top
Distance between centers	1200 mm
Working diameter	
- over guideway	560 mm
- over support	450 mm
Spindle speed, stepless	0 - 1200 rpm 0 - 3200 rpm
Speed steps	stepless, 2 steps
Spindle thread	M 33 x 3,5 mm
Tailstock	
Taper of tailstock sleeve	MT 2
Travel of tailstock sleeve	110 mm
Motor power output S ₁ 100%	1,5 kW (2,0 HP)
Motor power input S ₆ 40%	2,2 kW (3,0 HP)
Voltage	230 V
Machine dimension (W x D x H)	2100 x 550 x 1300 mm
Weight approx.	212 kg
Art. no.	10-1184



The powerful drive motor guarantees high torque even at low speed.



High-quality frequency converter allows for stepless adjustment of the spindle speed.



The spindle unit can travel longitudinally and can be locked into any position.

HCL 1200 Top

The HCL 1200 Top lathe features an electronic, steplessly adjustable speed setting as part of the standard accessories which allows ideal adjustment to each workpiece. This model is predominantly used among experienced, high-level amateurs. Compared to the HCL 1200, this model offer a bigger turning diameter.



Thanks to the optional glide bowl turner's toolrest set, a wide variety of machining operations can be carried out quickly and easily.

The outboard turning device ensures hassle-free processing of large workpiece diameters (Ø 920 mm).



**Best
Price**

Optionally available: copying device Deluxe for efficient copying of original parts or templates.

Standard accessories:

- Tool rest 360 mm
- Face plate 150 mm
- Live center
- Spore drive center
- Frequency inverter
- Tools

**Serially equipped with
left and right turning**

Optional accessories:

	Art. no.	excl. VAT
Outboard turning attachment	10-4002	
Copying device Deluxe	10-1116	
Collet chuck system M 24 / M 33, 6 pcs.	10-5050	
Drive center set M 33 x 3,5, 7 pcs.	10-5051	
Glide bowl turner's toolrest set 4 pcs.	10-5062	
Power chuck set Premium M 115	10-5064	
4-jaw independent chuck 150 mm / M 33	10-6000	

Optional accessories:

	Art. no.	excl. VAT
Self-centering chuck 40 / 70, M 33 x 3,5 mm	10-6020	
Chuck M 115 with dovetail jaws type A	10-6054	
Profi-chisel set HSS, 6 pcs. / set A	10-7001	
Profi-chisel set HSS, 8 pcs. / set B	10-7002	
Mini-chisel set HSS, 5 pcs. / set E	10-7006	
Economy live center PC - MT 2	22-1001	
Sweeper for woodturning lathe	10-4003	

BERNARDO®
www.bernardo-spain.com

Si tiene más preguntas, no dude en contactar con nuestro centro de atención al cliente +34 652 62 99 91

Your dealer

BERNARDO[®]
www.bernardo-spain.com

Bernardo Spain

Barcelona | 08800 Vilanova i la Geltrú | Rambla de la Exposición, 59

Tel. +34 652 62 99 91 | E-mail: info@bernardo-spain.com

www.bernardo-spain.com

PIE DE IMPRENTA:

Todos los derechos reservados: la reproducción de imágenes o textos o partes de éstos está estrictamente prohibida a menos que se acuerde previamente con PWA. Reservado el derecho a realizar modificaciones técnicas y ópticas. Las especificaciones del producto están sujetas a cambios sin previo aviso. No se asumirá ninguna responsabilidad por errores o fallos de impresión. Las máquinas se muestran parcialmente con extras opcionales. Edición 02/2022.